

Snap Breaker SBH-2

◆ Specifications

Model	Full Length mm	Weight kg	Cylinder Output kN	Clearance (A) mm
SBH-2	848	59	225	56

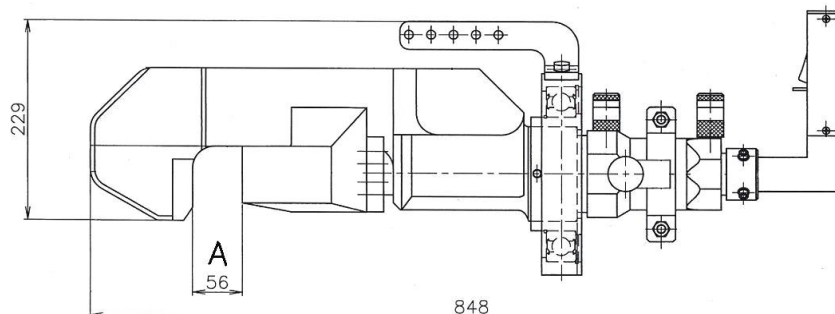

◆ Applications

Snap Breaker is developed to break down lengthy runners into small pieces so that furnace can melt these efficiently. By using this Snap Breaker, you can offload heavy labor, noise, and ineffectiveness of grinding and gas cutting.



◆ Features

- Maximum breakable cross-section:
FC200: ϕ 54mm
FCD450: ϕ 54mm
- This machine has high breaking power and mobile operability, and suitable to medium size applications



* Specifications may change without any notice for product improvement.