

# Snap Breaker SBH-1L

## ◆ Specifications

Model	Full Length mm	Weight kg	Cylinder Output kN	Clearance (A) mm
SBH-1L	781	38	185	70

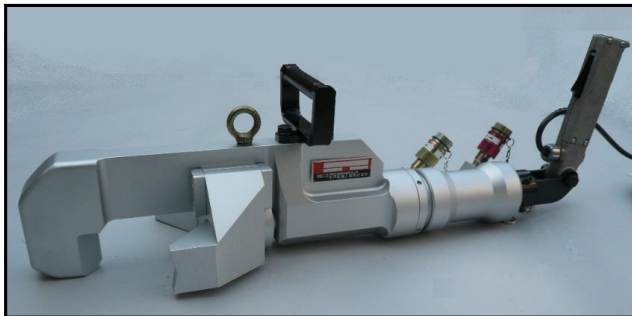
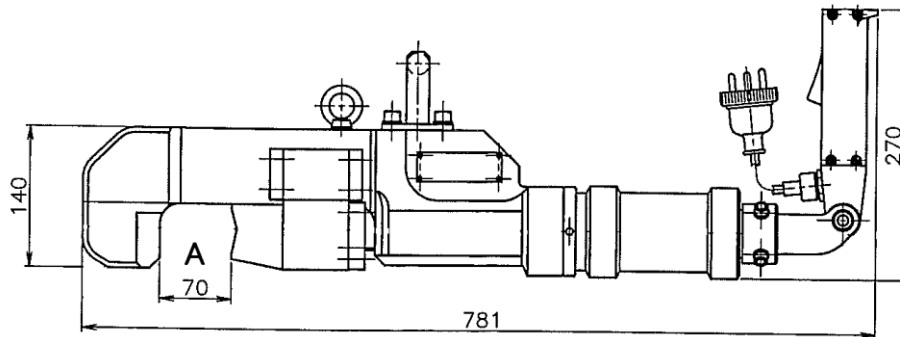

## ◆ Applications

Snap Breaker is developed to break down lengthy runners into small pieces so that furnace can melt these efficiently.

By using this Snap Breaker, you can offload heavy labor, noise, and ineffectiveness of grinding and gas cutting.

## ◆ Features

- Maximum breakable cross-section:  
FC200:  $\phi$  55mm  
FCD450:  $\phi$  48mm

○ This machine is developed by customers demand for medium size of Snap Breaker between SBH-1 and SBH-2.



\* Specifications may change without any notice for product improvement.